

**INDUSTRIAL**
**Paper roll**

**PR0783**  
white epoxy finish



**PR0783C**  
bright finish



**PR0783CS**  
satin finish

**General Description:**

- Circular toilet paper dispenser for industrial rolls of 250/300 m, surface mounted.
- Manual dispensing.
- Robust and vandal-proof.
- Suitable for very high traffic facilities.
- Model suitable for public use with high strength and durability.

**Technical specifications:**

<b>Dimensions</b>	$\varnothing$ 250 x 125 mm
<b>Paper roll capacity</b>	Max. $\varnothing$ 230 mm
<b>Thickness of body and lid</b>	0,8 mm
<b>Weight (empty)</b>	1,3 kg
<b>Toilet roll width</b>	Max. 115 mm
<b>Toilet roll tube</b>	Min. $\varnothing$ 45 mm

**Materials & components:**

- **PR0783:** steel, 0.8 mm thick, white epoxy finish.
- **PR0783C:** stainless steel AISI 304, 0.8 mm thick, bright finish.
- **PR0783CS:** stainless steel AISI 304, 0.8 mm thick, satin finish.
- One-piece body, 0,8 mm thick, round  $\varnothing$  250 mm, fully sealed and with a catch system to prevent the opening of the door. The supports of the screws in the back of the appliance, are acting as an anti-moisture support, as well as slots to avoid the screws damaging the toilet paper. It is mounted on the wall by means of 3 wood screws with their corresponding 5 mm wall plugs. It includes a lock system with standard mediclinics® key, that allows opening the lid for replenishment.
- Stainless steel AISI 304 shaft, 0.8 mm thick, for standard 45 mm paper roll tube, with inertial anti-spin retainer. The axis allows the use of a standard paper roll in case of need.
- One-piece seamless lid, 0.8 mm thick, fully sealed. Fixed to the body by means of rivets that allows swinging down of the lid for the replenishment.
- Frontal window indicates refill time.

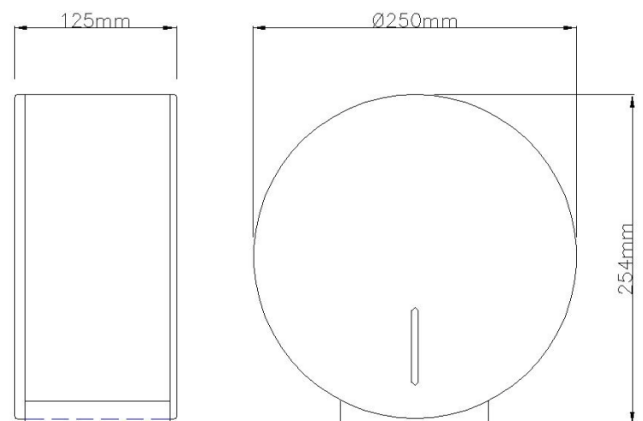
**Dimensions**

**MOUNTING TEMPLATE**

65-75 cm at lower point // 70 cm at lower point (for handicapped people).